



Loop

ENERGY MALAYSIA
Company Profile

Renewable Energy Solution Company



ABOUT US

Loop

ENERGY MALAYSIA

Loop Energy Malaysia Sdn Bhd, an overseas subsidiary of Loop Inc, is one of Malaysia's market leader in the renewable energy sector. We specialize in providing comprehensive solutions for commercial & industrial segment, as well as large scale solar.

Since 2018, we're driven our parent company's vision to expand beyond Japan's borders. Our journey began with PV module trading, catering to both local and international markets. Recognized as a registered RPVI by SEDA, we ventured into OPEX (PPA) in 2022, along with CAPEX services for commercial and industrial clients.

At Loop Energy Malaysia, we're propelling sustainable energy adoption, underscoring our commitment to innovation, environmental stewardship, and exceptional service.

LOOP ENERGY MALAYSIA SDN. BHD.

📍 Level 13, Q Sentral, 13-05,
2A, Jalan Stesen Sentral 2,
Kuala Lumpur Sentral,
50470 Kuala Lumpur,
Malaysia

☎ (+60) 3 2276 2754
✉ enquiry@loop.my

LOOP INC. (HEAD OFFICE)

📍 Ueno Frontier Tower,
3-24-6, Ueno, Taito-ku,
Tokyo, 110-0005 Japan

☎ (+81) 3 4577 9001
✉ info@loop.co.jp

OUR VISION

Loop dedicates itself to a comprehensive 360-degree service, united by the vision of a society unburdened by energy constraints. Guided by our expertise and technological prowess, we relentlessly pursue inventive breakthroughs.

Our mission compels us to create cutting-edge energy solutions for a world where renewable resources take center stage. Through this commitment, we aspire to empower all individuals with access to abundant, liberated energy.

The Concept of

“CIRCULATING ENERGY”

with the three O's representing
Sunlight, Wind and Water.

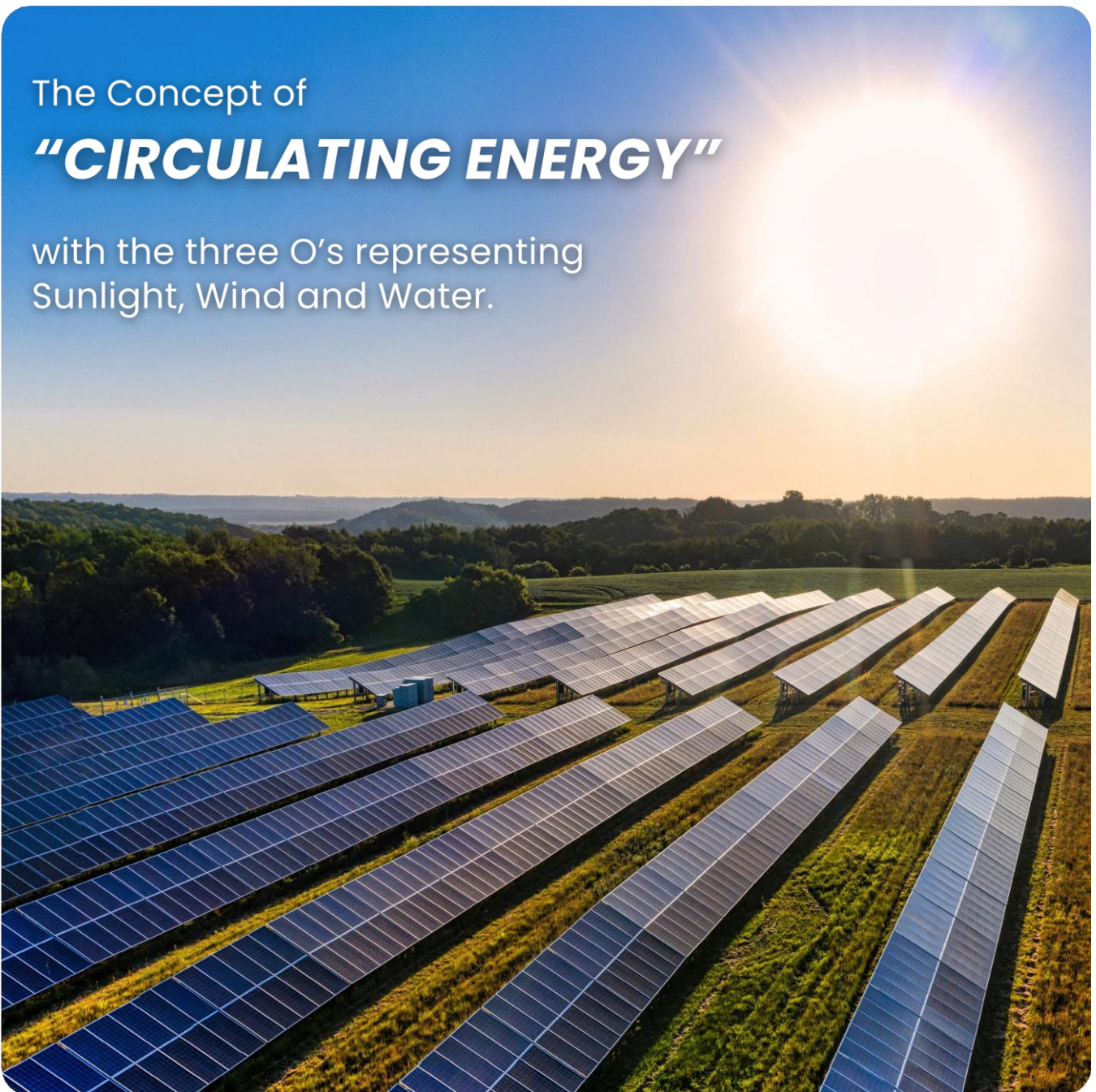

MILESTONE ACHIEVEMENT

2018
~
2021

- LEM established as Loop Inc.'s first overseas subsidiary.
- Started with PV Module trading.
- Registered as a Photovoltaic Investor (RPVI) under SEDA.

2022

- Expanded the business to include CAPEX & PPA projects.
- Achieved 110 million Ringgit in sales.

Delivered a 351.4kWp Solar BIPV PPA Project.



Delivered a 265.98kWp Solar PV CAPEX project.



Delivered a 40.28 kWp Solar + 500 kWh BESS for C&I project.



2023

Introduced Battery Energy Storage Systems (BESS) for Commercial and Industrial (C&I) market.

Loop

ENERGY MALAYSIA

Delivered a 1.3MWp rooftop project with bifacial panels and elevated mounting in Philippines.



Delivered a 326.34kWp solar PV with DC-coupling to 430kWh BESS project.



Delivered a 400 kW/ 860 kWh BESS project.



2024

2025

Delivered a 378.51kWp solar PV rooftop project with 250kW/ 500kWh BESS for off grid backup for Philippines government.



Commencing installation of a 30MWp solar farm with 4.3MWh BESS in Philippines.



Delivered a 499.23kWp solar rooftop project using flexible solar panels.



Launched Original Noah Power Cabinet for C&I market.

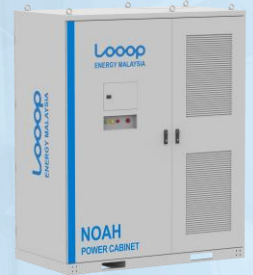

COMPLETED PROJECT

Lim Yu Yang
Project Engineer



BIPV Rooftop Solar PV System

System Type: BIPV System
System Size: 351.54 kWp BIPV Solar PV
Commission Date: October 2022
Project Location: Penang, Malaysia

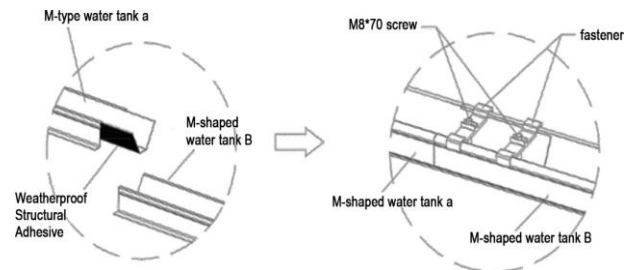

A tailored solution was provided as the client faced severe rooftop leakage that would normally require costly repair or replacement. An innovative M-Type Water Tank System was integrated to redirect rainwater to gutters, resolving the issue without roof replacement. The system now delivers up to **72% consumption offset** in monthly TNB bill and has outperformed expectations, **generating 108% above designed output**.



Standard Rooftop Solar PV System

System Type: C&I PV System
System Size: 265.98 kWp Solar PV
Commission Date: October 2022
Project Location: Penang, Malaysia



This Solar PV system supported the client in securing NEM and GITA approvals to recover 100% of system costs via tax allowance (up to 70% of taxable income in the first year). Nearly three years since commissioning, the system continues to outperform, averaging **110% of designed output** and offsetting about 58% of the client's electricity bill.

COMPLETED PROJECT

Lim Yu Yang
Project Engineer



Rooftop Bifacial Solar PV System

System Type: C&I Bifacial PV System
System Size: 1,297.10 kWp Solar PV
Commission Date: October 2023
Project Location: Clark, Philippines

In the year of 2023, we ventured into international market with **overseas CAPEX** project, marking the 1st **rooftop Double Glass Solar PV System** in the region.

Our innovative solution involved **elevated mounting structure** to fully harness the potential of Bifacial Solar PV System.

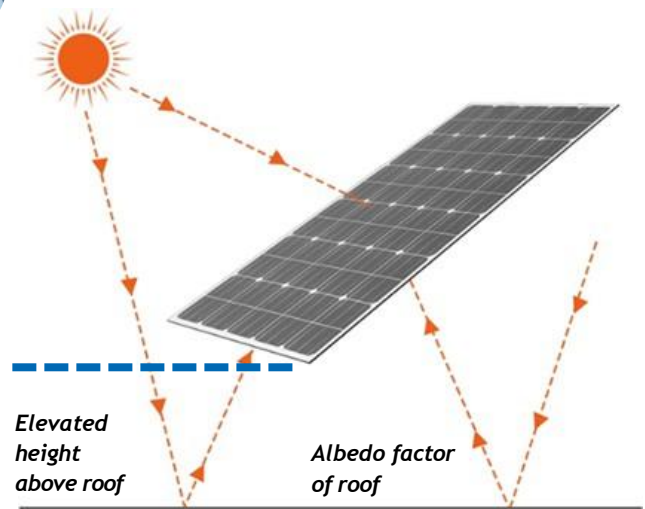

By factoring in the **albedo effect**, our expert engineering team maximized energy yield. We applied a unique yet efficient approach to amplify reflections, boosting energy output by **12.80%**. Combined with high solar irradiance (PSH4.5 ~ 5) and high tariff rates in the region, this system offers client a faster ROI, proving the design value of our company.



Results based on actual Energy Production in the region

COMPLETED PROJECT

Yoon Tjun Hung
Project Engineer



Standard Rooftop Solar PV System

System Type: C&I PV System
System Size: 180.4 kWp Solar PV
Commission Date: December 2023
Project Location: Selangor, Malaysia

LEM's Proprietary Power Factor Regulator

This customer's operations involve bending and forming machines that create intermittent power spikes, leading to an **unstable power factor**. A **conventional capacitor bank will not be able to react to these fluctuations** fast enough, causing inefficiencies and potential power factor penalties. To address this, LEM proposed installing a **proprietary solution**, which provides **fast, real-time power factor correction**. This solution will stabilize the power factor, improve energy efficiency, and help reduce operational costs without impacting the performance of the solar PV system.



🕒 **TEMPOH BIL**
01.03.2024 - 31.03.2024
(31 Hari)

MARCH 2023

Maklumat Tambahan Untuk Anda

Beban Diisytiharkan	681.70kW
Kehendak Maksima Tertinggi	346.00kW
Faktor Beban	0.12
Angkadar Kuasa	0.81

🕒 **TEMPOH BIL**
01.04.2024 - 30.04.2024
(30 Hari)

APRIL 2023

Maklumat Tambahan Untuk Anda

Beban Diisytiharkan	681.70kW
Kehendak Maksima Tertinggi	346.00kW
Faktor Beban	0.11
Angkadar Kuasa	0.94

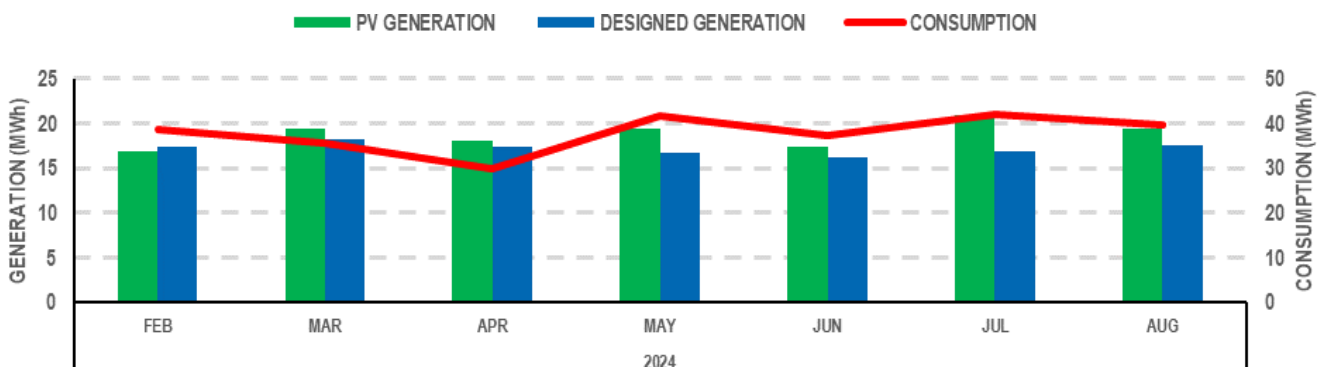

Designed generation based on OpenSolar meteorology PVWatts

***Actual Generation exceeded Design Generation by 109.08%

COMPLETED PROJECT

Ong Wei Chun
Project Engineer



Rooftop Flexible Solar PV System

System Type: C&I Flexible PV System
System Size: 499.66 kWp Solar PV
Commission Date: November 2024
Project Location: Selangor, Malaysia

Challenges:

Structural report shows that client rooftop is **not recommended** to install **conventional solar** by independent Certified Engineer. Require extensive reinforcement which **includes high cost & incur factory downtime and opportunity cost.**

Analysis Output Summary (Model 1)

Roof Truss GL N/3-12

The analysis output can refer to appendix (Staadpro Model)
Utilization Ratio shall be ≤ 1

i. UB 838x292x176 Tee (Beam No.99)	= 1.7648 > 1	FAIL
ii. UB 838x292x194 Tee (Beam No.78)	= 1.6897 > 1	FAIL
iii. UB 838x292x176 Tee (Beam No.77)	= 1.0211 > 1	FAIL
v. UB 838x292x194 Tee (Beam No.45)	= 1.9154 > 1	FAIL
v. UB 838x292x176 Tee (Beam No.50)	= 0.5238 > 1	PASS

In overall, the analysis is FAIL. Therefore, solar panel are not recommended to install on the top of the roof.

Value Added Service:

Upon agreement with client and client's building contractor, LEM proposed to install our **first flexible solar panel** that is 2.7kg/m² only.



Achieved:

35% instantaneous realized **project cost savings**, undisclosed **production & opportunity cost savings.**

LEM successfully helped our client to not only **save cost for reinforcement** for their rooftop and **avoid factory downtime** but also help them achieved their targeted **sustainability goals.**

COMPLETED PROJECT

Lim Yu Yang
Project Engineer



Containerized BESS + Rooftop PV

System Type: C&I BESS + PV System
System Size: 250 kW/ 500kWh BESS+ 40.28 kWp Solar PV
Commission Date: April 2023
Project Location: Selangor, Malaysia

First Sale of Battery-Energy Storage System (BESS) in Malaysia

This project marked LEM's **first sale of Battery-Energy Storage System (BESS) in Malaysia**, positioning us as one of the country's leading BESS solution providers.

Peak Shaving strategy

Our engineering team delivered a highly customizable and cost-effective solution, leveraging **Time-Of-Use (TOU)** electricity rates and **Peak Shaving strategy**. As a result, we reduced the client's maximum demand from 235 kW to 203kW (refer to TNB bill below), achieving a 32kW reduction monthly.

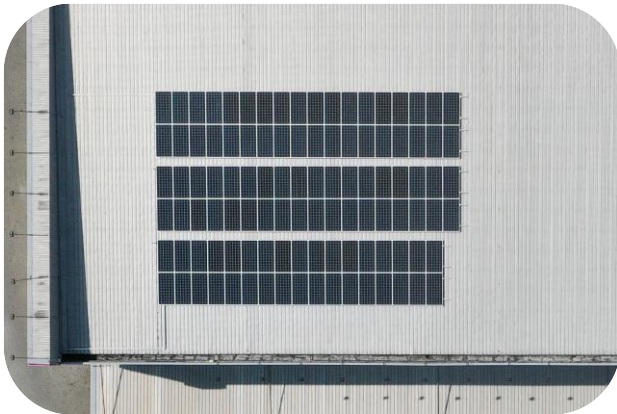

Uninterrupted Power Supply (UPS)

Beyond Peak Shaving, the BESS can also function as a **reliable Uninterrupted Power Supply (UPS)**, powering the client's operation for up to 4 hours during electricity blackout. This feature ensures continuous business operations, preventing potential income losses.

JAN 2023

MAKLUMAT BAYARAN AKHIR
 Amaun : RM
 Tarikh : 16.01.2023
Anda Guna

Penerangan	Penggunaan
Puncak (kWh)	65,503.00
Luar Puncak (kWh)	27,954.00
Kehendak Maksima (kW)	235.00
Jumlah	

JAN 2024

MAKLUMAT BAYARAN AKHIR
 Amaun : RM
 Tarikh : 17.01.2024
Anda Guna

Penerangan	Penggunaan
Puncak (kWh)	53,249.00
Luar Puncak (kWh)	40,100.00
Kehendak Maksima (kW)	203.00
Jumlah	

COMPLETED PROJECT

Yoon Tjun Hung
Project Engineer



Containerized BESS + BIPV Carport

System Type : BESS DC Couple System + BIPV Carport
System Size: 250kW/500kWh BESS + 378.51kWp Solar PV
Commission Date: December 2023
Project Location: Leyte, Philippines

In December 2023, Loop Energy Malaysia successfully deployed a solar photovoltaic (PV) and Battery Energy Storage System (BESS) at the Leyte Provincial Government Complex. This system delivers a **sustainable renewable energy solution** while **addressing the frequent power outages** in the province, which occur multiple times a week.

During normal operation, The BESS is designed to support customer's load when the PV generation is not able to fully support customer's consumption. When PV generation exceed customer's consumption, excess generation will be used to charge the BESS.

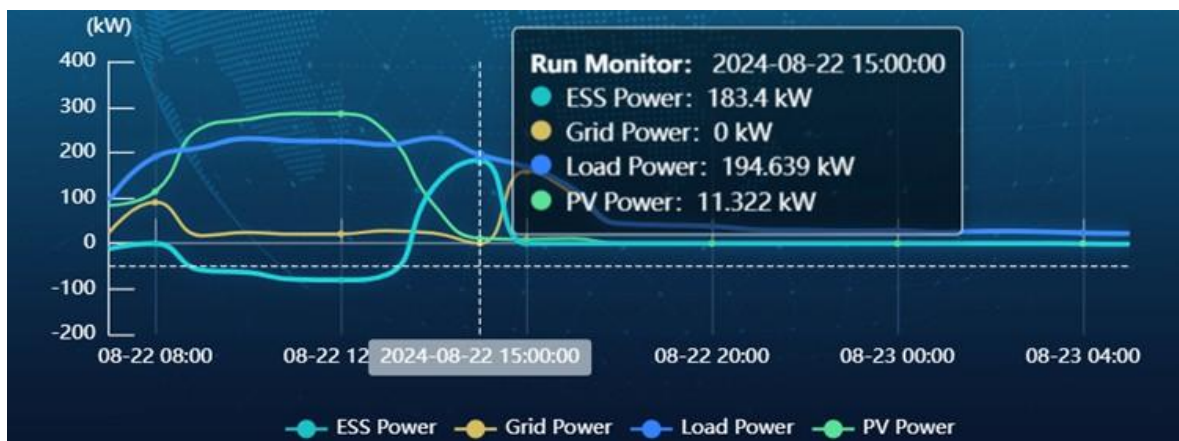

PV+BESS System Off-Grid Support

LEM seamlessly integrated the PV + BESS system with the existing power infrastructure, which utilizes both grid power and a backup generator. This integration is made possible through the deployed **Energy Management System (EMS)** and the installation of a **motorized breaker** in coordination with the customer's Automatic Transfer Switch (ATS). This configuration enables the **BESS to discharge during power outages**, supporting the complex's energy needs. In the event of prolonged outages where the BESS becomes depleted, the customer's generator steps in to support client's energy needs, ensuring full energy resilience.

COMPLETED PROJECT

Yoon Tjun Hung
Project Engineer



PV & Storage Hybrid Battery System

- System Type :** Rooftop Solar + BESS DC Couple System
- System Size:** 326.340 kWp Solar PV + 300kW/430kWh BESS
- Commission Date:** December 2024
- Project Location:** Pampanga, Philippines

AC-Coupled PV + BESS System

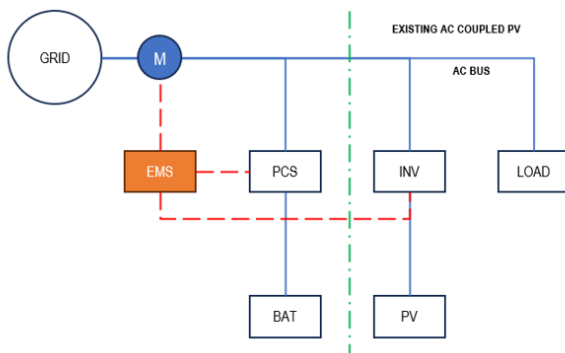

DC-Coupled PV + BESS System

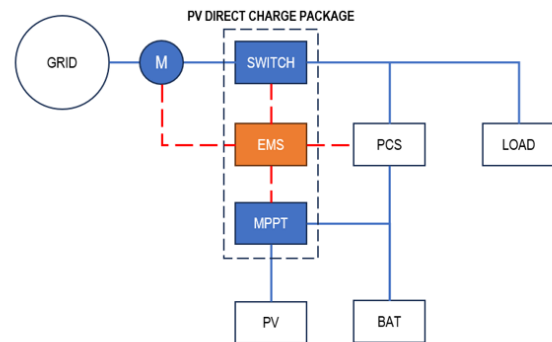

In December 2024, LEM successfully deployed a DC-Coupled Solar Photovoltaic (PV) and Battery Energy Storage System (BESS) in Pampanga, Philippines. By utilizing a DC-coupled configuration, the system achieves **higher efficiency** compared to conventional AC-coupled setups, as energy flows directly from the PV to the BESS with reduced conversion losses. This ensures customers gain maximum value from their renewable energy investment while supporting a sustainable and reliable power supply.



PV + BESS System Off-Grid Support

LEM seamlessly integrated the DC-Coupled PV + BESS system with the customer's existing power infrastructure. The system is equipped with a Static Transfer Switch (STS) that enables **seamless switching** between on-grid and off-grid modes. During power outages, the BESS immediately discharges to support the facility's energy needs, with a transfer time of **less than 20ms**. This configuration ensures uninterrupted operations and reliable backup power without the need for a generator, providing customers with a fully renewable and resilient energy solution.

COMPLETED PROJECT

Ryan Leong
Project Engineer



Cabinet type Storage Battery System

System Type : C&I BESS System
System Size: 400kW/860kWh BESS
Commission Date: December 2024
Project Location: Negeri Sembilan, Malaysia

Loop Energy Malaysia proudly presents our latest innovation in energy storage — a compact and easy-to-install Battery Energy Storage System (BESS) designed for modern energy needs.

At the heart of our system is an advanced operating technology known as **Dynamic Peak Shaving**. This intelligent feature allows users to automatically manage energy demand in two powerful ways:

Time-Based Peak Shaving: Schedule peak shaving during specific times of the day to reduce energy costs during high-tariff periods.

Load-Based Peak Shaving: Automatically activate battery support when your energy consumption exceeds a predefined kW threshold.

This dual-mode operation maximizes the efficiency of every charge cycle, ensuring that more battery power is reserved for when it's needed most — whether during peak usage hours or unexpected demand surges. With smart energy management and an installation-friendly design, LEM's battery system empowers users to take greater control of their energy usage, reduce costs, and contribute to a more sustainable future.

BEFORE BESS

Penerangan	Penggunaan
Penggunaan (kWh)	460,152.00
Kehendak Maksima (kW)	1,248.00

AFTER BESS

Penggunaan Anda		
Puncak	kWh	84,517.00
Luar Puncak	kWh	215,586.00
Permintaan Maksima	kW	1,076.00

With 4 units of BESS cabinets, a total of 860 kWh of battery capacity, Loop's BESS is capable of reducing up to 170 kW of Maximum Demand (MD) through dynamic peak shaving - delivering significant demand charge savings without the need for oversized systems.

ON-GOING PROJECT

Lim Yu Yang
Project Engineer



Large Scale Solar Farm + Utility BESS

System Type:	Large Scale Solar (LSS)
System Size:	29,952 kWp Solar Farm + 4,386 kWh BESS
Expected Commission Date:	Q4 2025
Project Location:	Ilocos Norte, Philippines

In 2024, our company entered the overseas Large-Scale Solar (LSS) sector with a landmark project in Nueva Era, Philippines.

This global collaboration—drawing expertise from Malaysia, Japan, Germany, China, and the Philippines—launched in May 2024 and features a **29.952 MWp Double Glass Solar PV System integrated with a 4.386 MWh Battery Energy Storage System (BESS)**, the first of its kind in the country.

Designed to enhance energy reliability and stability, the system is projected to generate **48.926 GWh annually**, with **917 MWh stored for efficient, on-demand distribution**, including during peak hours or at night. Electricity will be supplied directly to Ilocos Norte Electric Cooperative (INEC), bypassing the national grid.



This setup is expected to save INEC approximately PHP 40 million by cutting PHP 1/kWh in transmission costs, potentially transforming the local electricity market with lower tariffs and more affordable energy for the community.



OUR BESS KEY BENEFITS -NOAH POWER CABINET-

Noah Power Cabinet -100kW/215kWh-



The **NOAH POWER CABINET** delivers reliable and flexible Battery Energy Storage System (BESS) solutions. With strong in-house engineering expertise, we manage the entire process, from design to installation and commissioning- customized to your site and goals.



Peak Shaving Solution

-Efficient control for Maximum savings-

Designed for peak shaving, the BESS Cabinet charges during off-peak hours and discharges during peak hours following your load, reducing energy costs and optimizing efficiency.

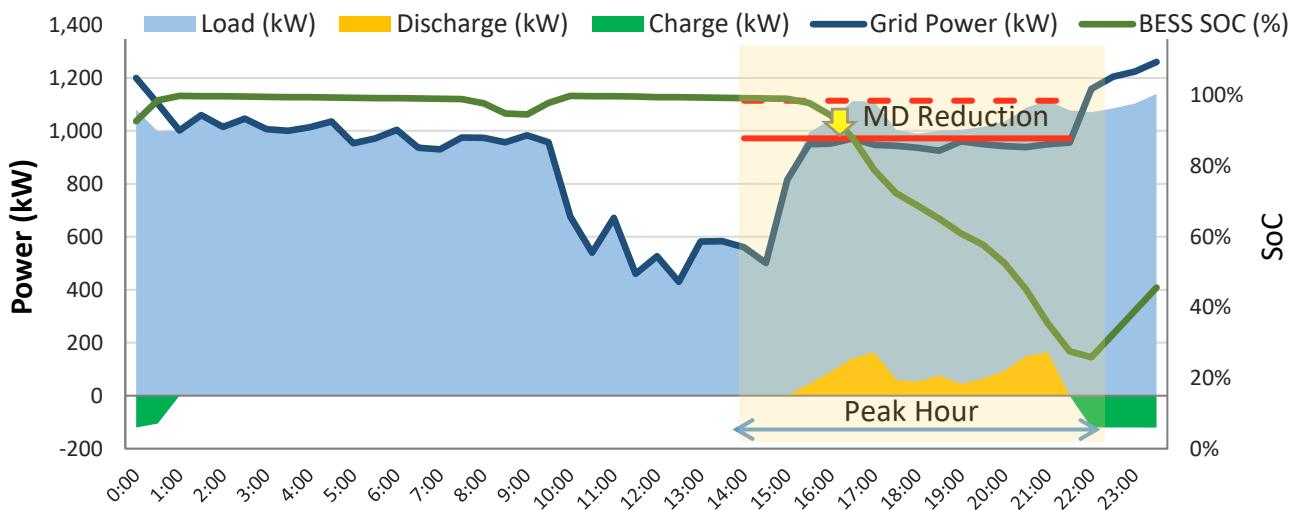

Flexible Charge & Discharge Rate for Optimized Performance

Our BESS system adapts its charge and discharge rates based on specific application needs, ensuring optimal performance in all situations. LEM customizes each BESS solution to meet customer requirements, whether for **fast power delivery or efficient energy storage**, guaranteeing the **best operational efficiency** for any application.

Seamless On-Grid and Off-Grid Transition

Our BESS operates efficiently in both on-grid and off-grid modes. With proprietary technology, it performs a **rapid 20ms switch** between grid power and backup during outages, ensuring **uninterrupted operation**. When grid power returns, the system switches back seamlessly without any disruption. This makes our BESS an excellent UPS alternative for critical facilities such as data centers, offering higher capacity, full load support, and lower maintenance through advanced **LiFePO4 battery technology**.



One-stop Renewable Energy Solution Provider